

2300

20V N-Channel Enhancement-Mode MOSFET

General Description

- $I_D=5.2A$
- $R_{DS(on)}=18m\Omega(Typ.)@V_{GS}=10V$
- $R_{DS(on)}= 29m\Omega(Typ.)@V_{GS}=4.5V$
- Advanced high cell density Trench technology
- Super low gate charge
- Excellent Cdv/dt effect decline
- Application:
 - High frequency point-of-load synchronous
 - Load switch
 - PWM applications
- Lead free and green devices are available
- Package: SOT23

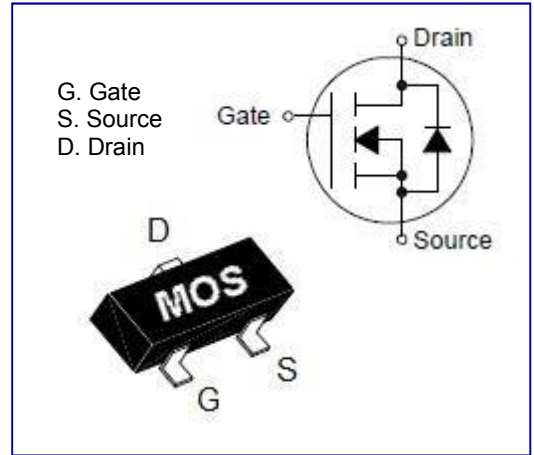

Absolute Maximum Ratings ($T_A=25^\circ C$ unless otherwise noted)

Parameter		Symbol	Limit	Unit
Drain-Source Voltage		V_{DS}	20	V
Gate-Source Voltage		V_{GS}	± 12	V
Drain Current ^a	$T_C=25^\circ C$	I_D	5.2	A
	$T_C=70^\circ C$		4.0	
Drain Current –Pulsed ^a		I_{DM}	15	A
Power Dissipation ($T_C=25^\circ C$)		P_D	0.9	W
Power Dissipation ($T_C=75^\circ C$)			0.5	
Storage Temperature Range		T_{STG}	-55 ~ +150	$^\circ C$
Operating Junction Temperature Range		T_J	-55 ~ +150	$^\circ C$
Thermal Resistance, Junction-to-Ambient1		$R_{\theta JA}$	100	$^\circ C/W$

Electrical Characteristics ($T_A=25^\circ C$ unless otherwise noted)

Parameter	Symbol	Condition	Min	Typ	Max	Unit
Off Characteristics						
Drain-Source Breakdown Voltage	BV_{DSS}	$V_{GS}=0V, I_D=250\mu A$	30	---	---	V
Zero Gate Voltage Drain Current	I_{DSS}	$V_{DS}=20V, V_{GS}=0V$	---	---	1	μA
Gate-Body Leakage			I_{GSS}	$V_{GS}=\pm 10V, V_{DS}=0V$	---	---
On Characteristics ^a						
Gate Threshold Voltage	$V_{GS(th)}$	$V_{DS}=V_{GS}, I_D=250\mu A$	1.0	1.5	2.0	V
Drain-Source On-State Resistance	$R_{DS(on)}$	$V_{GS}=10V, I_D=5.0A$	---	18	25	m Ω
		$V_{GS}=4.5V, I_D=4.0A$	---	29	35	m Ω
Forward Transconductance	g_{fs}	$V_{DS}=5V, I_D=2A$	---	15	---	S
Drain-Source Diode Characteristics ^a						
Continuous Source Current	I_S	$V_G=V_D=0V, \text{Force Current}$	---	---	5.2	A
Pulsed Source Current	I_{SM}		---	---	15	A

2300

Diode Forward Voltage	V_{SD}	$V_{GS}=0V, I_S=1A$	---	---	1.3	V
Dynamic Characteristics ^b						
Input Capacitance	C_{iss}	$V_{DS}=15V, V_{GS}=0V, F=1.0MHz$	---	155	---	pF
Output Capacitance	C_{oss}		---	25	---	pF
Reverse Transfer Capacitance	C_{rss}		---	15	---	pF
Switching Characteristics ^b						
Total Gate Charge	Q_g	$V_{DS}=15V, I_D=5.2A, V_{GS}=10V$	---	5.2	---	nC
Gate-Source Charge	Q_{gs}		---	0.85	---	nC
Gate-Drain Charge	Q_{gd}		---	1.3	---	nC
Turn-On Delay Time	$T_{d(on)}$	$V_{DD}=15V, R_L=3\Omega$ $V_{GS}=10V, R_{GEN}=3\Omega$	---	4.5	---	ns
Rise Time	T_r		---	2.5	---	ns
Turn-Off Delay Time	$T_{d(off)}$		---	14.5	---	ns
Fall Time	T_f		---	3.5	---	ns

Notes: a. Repetitive Rating: Pulsed width limited by maximum junction temperature.
 b. Pulse test: pulse width $\leq 300\mu s$, duty cycle $\leq 2\%$. Essential independent of operating temperature.
 c. Guaranteed by design, not subject to production testing.

Switching Time Test Circuit and Waveforms

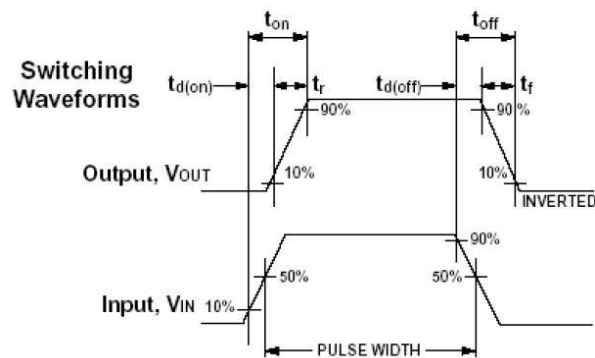
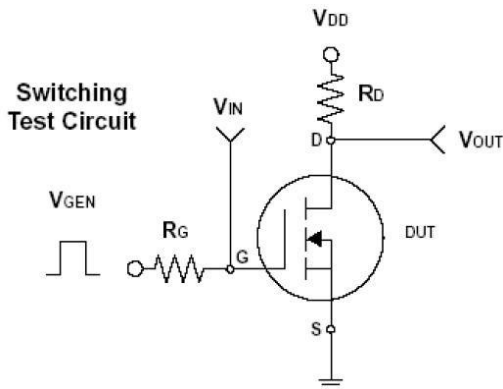

Soldering Methods For Products

1. Storage environment : Temperature=10°C ~ 35°C, Humidity=65% ± 15%
2. Reflow soldering of surface mount devices

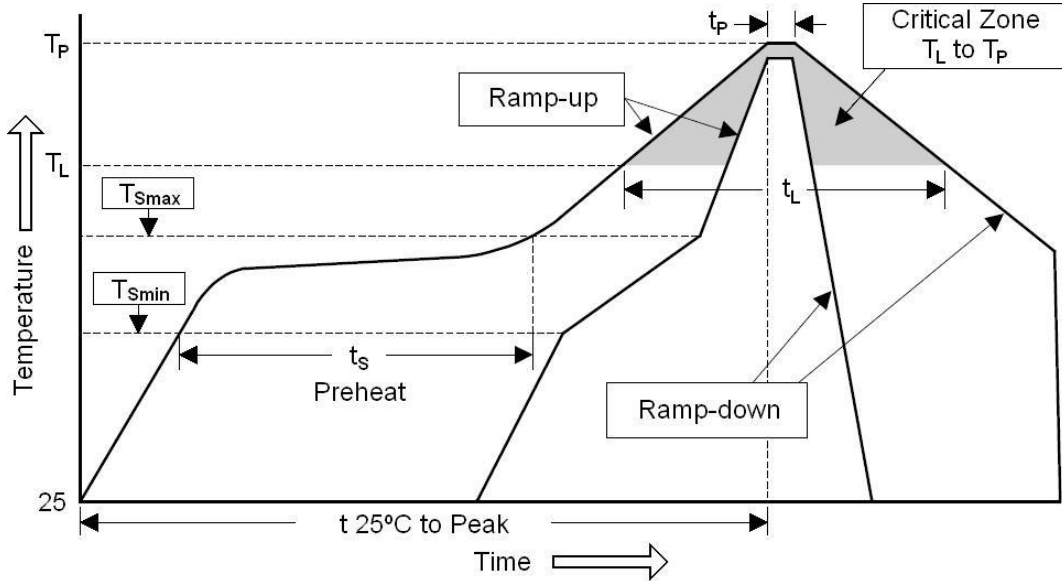

Figure : Temperature Profile

Profile Feature	Sn-Pb Eutectic Assembly	Pb-Free Assembly
Average ramp-up rate (T_L to T_P)	< 3°C/sec	< 3°C/sec
Preheat		
- Temperature Min (T_{Smin})	100°C	100°C
- Temperature Max (T_{Smax})	150°C	200°C
- Time (Min to Max) (t_s)	60 ~ 120 sec	60 ~ 180 sec
T_{Smax} to T_L		
- Ramp-up rate	< 3°C/sec	< 3°C/sec
Time maintained above:		
- Temperature (T_L)	183°C	217°C
- Time (t_L)	60 ~ 150 sec	60 ~ 150 sec
Peak Temperature (T_P)	240°C +0/-5°C	260°C +0/-5°C
Time within 5°C of actual Peak Temperature (t_p)	10 ~ 30 sec	20 ~ 40 sec
Ramp-down rate	< 6°C/sec	< 6°C/sec
Time 25°C to Peak Temperature	< 6 minutes	< 8 minutes

3. Flow (wave) soldering (solder dipping)

Product	Peak Temperature	Dipping Time
Pb devices	245°C ±5°C	5sec ±1sec
Pb-Free devices	260°C +0/-5°C	5sec ±1sec

Notices:

- All companies, brands, logos, pictures, product names and trademarks are the property of owner respective companies.
- 规格书内容、版本或参数规格如有更改恕不另行通知，如有特定规格的需求请事先告知，如因此而造成任何的问题，供应商不承担任何赔偿和法律责任。
- MOS 管电路是静电敏感元器件，且对生产环境要求较严，建议在存放及生产操作时一定要避免静电干扰，经锡炉或回焊炉的温度切勿超过 260 度。