

Transistor

NPN Transistors 2N3904

■ Features

- Collector current: $I_c=0.2A$
- Complementary to 2N3906

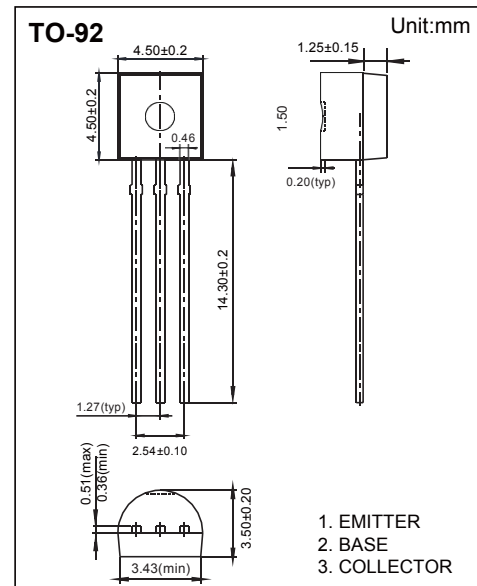

■ Absolute Maximum Ratings $T_a = 25^\circ C$

Parameter	Symbol	Rating	Unit
Collector - Base Voltage	V_{CBO}	60	V
Collector - Emitter Voltage	V_{CEO}	40	
Emitter - Base Voltage	V_{EBO}	6	
Collector Current - Continuous	I_c	0.2	A
Collector Power Dissipation	P_c	625	mW
Junction Temperature	T_J	150	°C
Storage Temperature	T_{stg}	-55 to 150	

Transistor

NPN Transistors

2N3904

■ Electrical Characteristics Ta = 25°C

Parameter	Symbol	Testconditons	Min	Typ	Max	Unit
Collecto- base breakdown voltage	V _{CBO}	I _c = 100 μA, I _E =0	60			V
Collector- emitter breakdown voltage	V _{CEO}	I _c = 0.1 mA, I _B =0	40			
Emitter - base breakdown voltage	V _{EBO}	I _E = 100 μA, I _C =0	6			
Collector cut-off current	I _{CBO}	V _{CB} = 60 V , I _E =0			0.1	μA
Collector cut-off current	I _{CEO}	V _{CE} = 40 V , I _B =0			0.1	
Emitter cut-off current	I _{EBO}	V _{EB} = 5V , I _C =0			0.1	
Collector-emitter saturation voltage	V _{CE(sat)}	I _C =50 mA, I _B = 5mA			0.3	V
Base - emitter saturation voltage	V _{BE(sat)}	I _C =50 mA, I _B = 5mA			0.95	
DC current gain	h _{FE(1)}	V _{CE} = 1V, I _C = 10mA	100		400	
	h _{FE(2)}	V _{CE} = 1V, I _C = 50mA	60			
	h _{FE(3)}	V _{CE} = 1V, I _C = 100mA	30			
Delay Time	t _d	V _{CC} =3V, V _{BE} =0.5V, I _C =10mA, I _{B1} =1mA			35	ns
Rise Time	t _r				35	
Storage Time	t _s	V _{CC} =3V, I _C =10mA			200	
Fall Time	t _f	I _{B1} =I _{B2} =1mA			50	
Transition frequency	f _T	V _{CE} = 20V, I _C = 10mA, f=100MHz	300			MHz

■ Classification of h_{FE(1)}

Rank	O	Y	G
Range	100-200	200-300	300-400

Transistor

NPN Transistors 2N3904

■ Typical Characteristics

