

Transistor

NPN Transistors 2N5551

■ Features

- Collector current: $I_c=0.6A$
- General Purpose Switching Application

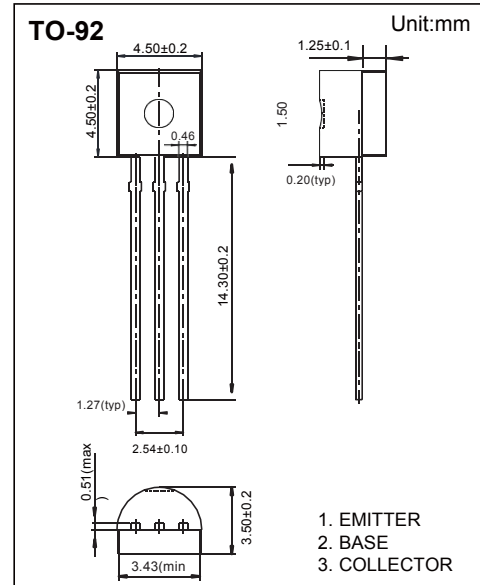

■ Absolute Maximum Ratings $T_a = 25^\circ C$

Parameter	Symbol	Rating	Unit
Collector - Base Voltage	V_{CB0}	180	V
Collector - Emitter Voltage	V_{CE0}	160	
Emitter - Base Voltage	V_{EB0}	6	
Collector Current - Continuous	I_c	0.6	A
Collector Power Dissipation	P_c	625	mW
Thermal Resistance From Junction To Ambient	$R_{\theta JA}$	200	$^\circ C/W$
Junction Temperature	T_J	150	$^\circ C$
Storage Temperature	T_{stg}	-55 to 150	

Transistor

NPN Transistors

2N5551

■ Electrical Characteristics $T_a = 25^\circ\text{C}$

Parameter	Symbol	Testconditons	Min	Typ	Max	Unit
Collecto- base breakdown voltage	V_{CBO}	$I_C = 100 \mu\text{A}, I_E = 0$	180			V
Collector- emitter breakdown voltage	V_{CEO}	$I_C = 1 \text{ mA}, I_B = 0$	160			
Emitter - base breakdown voltage	V_{EBO}	$I_E = 100 \mu\text{A}, I_C = 0$	6			
Collector cut-off current	I_{CBO}	$V_{CB} = 120 \text{ V}, I_E = 0$			50	nA
Emitter cut-off current	I_{EBO}	$V_{EB} = 4 \text{ V}, I_C = 0$			50	
Collector-emitter saturation voltage	$V_{CE(sat)}$	$I_C = 10 \text{ mA}, I_B = 1 \text{ mA}$			0.15	V
		$I_C = 50 \text{ mA}, I_B = 5 \text{ mA}$			0.2	
Base - emitter saturation voltage	$V_{BE(sat)}$	$I_C = 10 \text{ mA}, I_B = 1 \text{ mA}$			1	
		$I_C = 50 \text{ mA}, I_B = 5 \text{ mA}$			1	
DC current gain	$h_{FE(1)}$	$V_{CE} = 5 \text{ V}, I_C = 1 \text{ mA}$	80			
	$h_{FE(2)}$	$V_{CE} = 5 \text{ V}, I_C = 10 \text{ mA}$	80		300	
	$h_{FE(3)}$	$V_{CE} = 5 \text{ V}, I_C = 50 \text{ mA}$	50			
Collector output capacitance	C_{ob}	$V_{CB} = 10 \text{ V}, I_E = 0, f = 1 \text{ MHz}$			6	pF
Emitter input capacitance	C_{ib}	$V_{BE} = 0.5 \text{ V}, I_C = 0, f = 1 \text{ MHz}$			20	
Transition frequency	f_T	$V_{CE} = 10 \text{ V}, I_C = 10 \text{ mA}, f = 100 \text{ MHz}$	100		300	MHz

■ Classification of $h_{FE(2)}$

Rank		A	B	C
Range	80-100	100-150	150-200	200-300

Transistor

NPN Transistors

2N5551

■ Typical Characteristics

